

## Content:

Page 2  
Editorial  
Michael Mehnert

Page 3  
Continuation of the Article:  
BEKUM America Introduces  
the EBLOW 407 DL

PET Handleware  
Production Shifts into  
High Gear  
10 Machines Delivered in  
2017!

Page 4  
The fast clamping drive  
of the EBLOW 37

Page 5  
Research and development  
at SABIC with flexible  
BEKUM Co-Ex system

50 years of BEKUM in  
Austria

Page 6  
Martin Stark To Be  
Inducted Into The Plastics  
Academy Hall of Fame

Page 7  
Personalities

Page 8  
Polycarbonate water  
bottles

Publisher

## BEKUM America Introduces the EBLOW 407 DL

### Multi-Cavity Blow Moulding technology with 3-layer Co-Ex and magnetic quick change

Steven D. London President and COO comments on BEKUM's appearance at the NPE 2018 in Orlando: "Customers expect answers from BEKUM for the most effective and efficient blow moulding technology that specifically focuses on their production conditions and application."

To specifically address the growing market need for a "high speed, bottle maker," BEKUM has successfully introduced the 407 DL machine. This machine offers the benefits of a double-shuttle long stroke machine platen, however, with a focus on cost-efficient production of smaller bottles, espe-



EBLOW 407 DL

With the EBLOW 407 DL we are putting a system at the centre of our appearance at the NPE 2018, which offers an excellent price-performance ratio in the high-speed production of consumer packaging.

The North American blow moulding industry recognizes that the BEKUM "07" Machine Series offers a full-range of bottle production potential - small bottles through large handled products.

cially those for personal care products.

With the US-built 407 D and 607 D machine models, the 407 DL will include the patented C-Frame clamp design and is available in Electric (EBLOW) or Hydraulic (HYBLOW) versions as well as Hybrid versions tailored to customer specific needs.

**At NPE 2018, the EBLOW 407 DL version will be demonstrated running an 8 x 100 mm CLD production of a 1-liter**

## Editorial



Dear customers, partners and employees,

BEKUM has made significant advances in recent months. After the reorganisation in Europe, processes have stabilised and the financial success of the measures is apparent. **With the electrical EBLow 407 DL, the EBLow 707 D and the EBLow 807 D, we are now simultaneously launching three new machines on the market** and our portfolio of 3-layer spiral distribution blow heads especially for consumer packaging has been expanded.

We have reorganised the management team, as well as the manufacturing and assembly in the USA, while also strengthening our company with new employees and trainees as in Europe, in order to satisfy higher demand.

We have been certified in accordance with the new ISO9001:2015 standard in Europe and the USA, in order to raise our quality standards even further. In the sales department, we have beaten the competition in winning exciting projects and have full order books for both of our production locations for 2018. And last but not least, we had an extremely successful financial year in 2017 for the company group and will invest further in our future.

I would like to describe our new machines and innovations in greater detail: First of all, our **EBLOW 407 DL, which is especially optimised for the manufacturing of consumer packaging** and has been available in the electrical version for the first time since spring 2018. The clamp-

ing unit has been consciously limited to a clamping force of 200 kN, on the one hand to offer a competitive cost-output ratio, but particularly to achieve faster cycle times and energy savings thanks to weight optimisation. I am especially pleased to see the positive feedback that we have received from this, and that we have already been able to sell several machines to customers in the USA.

Our newly developed **3-layer spiral mandrel distributor head** also contributes to this. This particularly meets the requirements of cost optimisation and higher recycling of consumer packaging. **Thanks to savings in the masterbatch and virgin material, due to a higher proportion of recycled material or calcium carbonate in end products, the higher initial investment in a 3-layer production generally pay off after 1-3 years** (depending on the application scenario). And of course, the higher use of recycled material conserves our environment and its resources.

A decisive topic for manufacturers of packaging is also the ever more frequent product and/or mould changes. Therefore, together with the EBLow 407 DL, we have designed a **new quick-change system based on magnetic clamping plates**, that enables tool-free mould changes in 15 minutes per clamping unit.

Our second new development, the **EBLOW 707 D**, has emerged from the enhanced EBLow 607 D, **in order to optimally satisfy the increased requirements of handleware and small canisters**. This machine is, like the EBLow 407 DL, available as an electrical machine, with classic hydraulics or as a hybrid version, based on the customer's wishes and requirements. This machine has been on the market since autumn 2017 and has already been sold to three different customers in Europe.

The greatest innovation in this trio is however our **EBLOW 807 D**, with a closing force of 400 kN for blow moulds up to 1060 mm. The new construction size enables it to satisfy high output requirements of growing packaging markets, especially handleware. Here the clamping unit is also based on our proven and patented C-frame for perfect closing force distribution, to ensure the highest product qualities. The new system for quick-changing of blow moulds will also be available with the first customer deliveries of the EBLow 807 D end of 2018.

As you can see, lots of innovations are happening at BEKUM, and in order to continue this positive trend in the future, we the managing partners want to further invest in the company and have approved an **additional € 4,6 million investment package** for the expansion of the Traismauer location, new machine tools, production resources as well as IT systems. There are also exciting new projects in the pipeline in the development department, and the **hiring of employees** in the productive areas, development, sales and service is in full swing in order to grow further.

However, for all activities the most important consideration is that we focus on you, our customers. We want to offer you not only machines, but also convincing and individual solutions for your particular requirements. With this in mind, we would like to ask you to continue supporting us on our journey. Your continued trust in us and your individual requirements simultaneously offer us support and motivation.

With warm regards,

**Michael Mehnert**  
Managing Partner

Continuation of page 1

round, 3-layer HDPE personal care bottle in recyclable HDPE. BEKUM's introduction of the US-Manufactured EBLOW 407 DL machine at NPE 2018 will focus on the following key benefits:

- This machine offers the **Multi-Cavity production of a double-shuttle long stroke machine**, however with a focus on speed and cost-efficient production of smaller bottles
- Flexibility is provided with the **newly developed integrated quick mould change system** offering less than

15 minutes mould change per clamping unit without the use of tools.

- The use of **newly developed 3-layer Spiral flow head technology** for maximized middle layer HDPE PCR loading and precise circumferential wall distribution.
- With Electric (EBLOW) or Hydraulic (HYBLOW) versions as well as Hybrid versions, BEKUM can tailor the 407 DL machine to address specific customer requirements and operational/maintenance staff expertise.

#### Technical Machine Specifications of the EBLOW 407 DL :

Max. mould width:	860 mm
Max. mould length:	470 mm
Mould depth:	2 x 130 mm
Mould open daylight:	250 mm
Clamping force:	200 kN (22.4 US tons)

Please visit BEKUM's booth (W2127, West Hall) at NPE 2018 in Orlando Florida May 7 -11 to learn more about the EBLOW 407 DL machine and how you can "Profit from our Experience in High Output Machinery."

[cjwalls@bekumamerica.com](mailto:cjwalls@bekumamerica.com)

## PET Handleware Production Shifts into High Gear 10 Machines Delivered in 2017!

The extrusion blow molding of PET bottles integrating a true flow through handle identifiable as #1 recyclable PET has long been a packaging goal for consumer products groups.

The inherent challenge of parison formation with sufficient material hang strength resulted in the development of EBM-specific co-polyester resins, such as PETG. Extrusion blow molding grades of PETG have been commercially available for over 30 years, yet, unfortunately, these co-polyester materials are not readily managed in the established PET recycle infrastructure due to their lower drying and melting points.

Several major PET material suppliers have recently developed high I.V. PET grades with hang strength, toughness and reduced crystallization rates for extrusion blow molding.

In order to optimize our PET processing technology, BEKUM partnered with both the PET material suppliers and major North American converters to refine the EBM PET process to meet the PET handleware goals of the brand owner. From extrusion system design, mould construction, material drying, regrind reuse, and in-machine deflashing, the EBM PET process was thoroughly analyzed and validated.



2017 saw the production commercialization of 10 BEKUM HYBLOW 07-series double-station machines for the round-the-clock production of handled PET beverage bottles in fully #1 recyclable PET.

Please visit BEKUM's booth in the Bottle Zone (S14053, South Hall) at NPE 2018 in Orlando/Florida May 7 -11 to learn more about this exciting new technology and how you can "Profit from our Experience in PET Handleware."

[gcarr@bekumamerica.com](mailto:gcarr@bekumamerica.com)



## Research and Development

# BEKUM E-Motion-Drive Pro

## The fast clamping drive of the EBLow 37

The construction and arrangement of the clamping units shape the design of extrusion blow-moulding machines. The following are decisive for achieving the production goals:

- short clamping time
- short clamping force build-up time
- uniform distribution of clamping force
- orderly removal of the moulded parts from the mould

In general, hydraulic cylinders, electro-mechanical drives or hybrid drives can be used as clamping drives, which directly or indirectly move the two mould clamping plates. Depending on the choice of drive, the requirements are fulfilled to differing degrees.

Electro-mechanical solutions available on the market work mostly with a

crankshaft. The crankshaft does indeed enable high clamping speeds, however, has weaknesses in the build-up of the necessary clamping force at the end of the clamping stroke. For a good punching result, this clamping force time at the end of the clamping stroke, depending on the plastic material, must always be kept short, however. In accordance with this requirement, the crankshaft is inferior to a direct-acting linear actuator, due to the speed characteristics that influence it. With its E-Motion-Drive Pro, BEKUM offers a clamping drive that combines a fast clamping speed with full clamping force. The drive combination of an electro-mechanically actuated fast clamping movement and the integration of an axially hydraulic and direct-acting linear actuator for the power stroke of the clamping function has proven itself in BEKUM blow-moulding machines.

Plastics that are demanding for process technology, such as PP, PC, PA and PET, have been processed on the EBLow 37 in the BEKUM development lab in numerous applications with excellent punching results at high quantities. A consistently high and precise force exertion during the squeezing process improves the shaping and the product quality of the moulded parts.

The process always has the full clamping force available without alignment, independently of the changes in mould thickness after a mould change. Clamping force and speed can be freely adjusted and thus adapted to the process requirements.

**The E-Motion-Drive Pro offers a decisive benefit and presents a significant production advantage to BEKUM customers.**

w.lehmann@bekum.de



## Research and Development

# Research and development at SABIC

## with flexible BEKUM Co-Ex system

BEKUM recently installed a BA 34.2 type Co-Ex blow moulding system in the development lab of the world-famous material manufacturer SABIC, in Riyadh/Saudi Arabia. The Co-Ex machine, that SABIC ordered for material development research purposes, must satisfy a series of complicated technical requirements.

BEKUM developed a special extrusion head with a pre-distributor specifically for this project, that connects the extruders for the different layers. This makes it possible for SABIC to test different materials in 5 layers with only three extruders. The material melted in the three extruders can be fed to the five layers as required. For example, the plastic material from the extruder, that had previously still extruded material for the middle layer, is fed to the two layers for the outer and inner layers in the subsequent application and the material of the outer layer is moved into the middle layer.

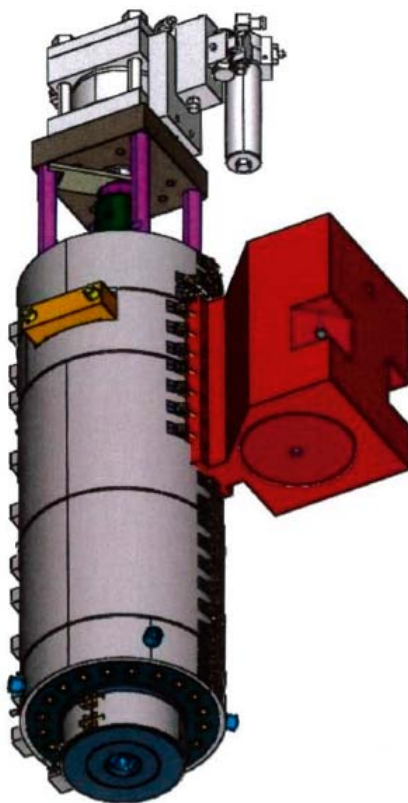

Co-Ex-head with pre-distributor

In addition to standard polyethylene, delicate plastics and plastics that are demanding for process technology, such as PP with and without EVA and PA as well as PC and PET, can be processed and tested in various layer thicknesses. The raw material usage is dosed by using a gravimetric dosing system. Furthermore, the production of differently-sized products, e.g. a 5 l bottle and a 20 l canister is possible. Switching between the 3-layer and 5-layer production processes is customer-friendly and can be performed with the shortest possible set-up time.

Thus a flexible Co-Ex lab machine has been developed that can create a multitude of different layer distributions, layer thicknesses and plastic materials in a space- and cost-saving manner, in order to satisfy the diverse research and development requirements of SABIC, in a variety of product sizes.

w.pawlowski@bekum.de

## Anniversary

## 50 years of BEKUM in Austria

With the founding of the production location in Traismauer in 1968, the founder and current managing partner Gottfried Mehnert expanded, alongside the headquarters established in Berlin, to Austria. With the assistance of their own mechanical production and the assembly of large blow-moulding machines for the manufacturing of canisters, technical parts and plastic fuel containers and other automotive components, BEKUM established an excellent worldwide reputation in Traismauer over the decades. Recently, BEKUM in Traismauer has successfully developed into the central European production location. All blow-moulding machines, whether electrical, hydraulic or hybrid, whether large or small for industrial and consumer



packaging, pharmaceuticals, automotive manufacturing or special applications, are manufactured at this modernised location on the Danube. BEKUMnews congratulates the com-

pany and its committed employees on the occasion of its 50th anniversary and wishes for the future continuous success.



## Special Award

# Martin Stark To Be Inducted Into The Plastics Academy Hall of Fame

Martin Stark, Chairman of BEKUM America Corporation is among a group of 10 distinguished individuals who will be inducted into the Plastics Hall of Fame during a ceremony that will take place on Sunday, May 6, 2018 at the National Plastics Exhibition (NPE) in Orlando/Florida, USA.

Martin has devoted more than 48 years of his professional career to the growth and internationalization of the plastics industry. His love affair with the industry began in 1969 when he immigrated to the United States from Germany. It was then that he began a successful career, initially at the Battenfeld Corporation of America in Skokie, Illinois, where he learned about the plastics industry, and developed his outstanding leadership skills. In 1981, Martin Stark moved to BEKUM America Corporation.

Through Martin's leadership, BEKUM America's reputation grew quickly, establishing the company as the most influential blow moulding manufacturer in North America, providing not only innovation and quality products, but also "world class service," a reputation it continues to maintain in today's highly competitive marketplace.



While growing BEKUM America as North America's top blow moulding manufacturer, Martin Stark continued his leadership in the Plastics Industry Association, expanding public awareness to the significant contributions the plastics industry has on our everyday lives, via launching open houses to the public to increase knowledge of

the benefits of plastic materials, including recyclability. Through his leadership, BEKUM developed ties to major US Universities and local Community Colleges.

Martin's proudest accomplishment was the introduction of a German-style four-year Apprenticeship Program, which has assisted BEKUM to "grow its own."

We congratulate Martin Stark to his induction in the Plastics Hall of Fame and we thank him for his extraordinary engagement for BEKUM and his developments in the plastics industry.

[johnston@bekumamerica.com](mailto:johnston@bekumamerica.com)



BEKUM America Corporation, Williamston/Michigan USA

## Personalities

Since Autumn 2017, the Sales department at BEKUM has welcomed three new employees. Bill Duckham was appointed Sales Director and wants to create some new momentum. With 20 years of experience in blow moulding, Werner Pawlowski has been appointed Global Sales Manager for the automotive, large packaging and technical parts industries. Stephan Gruber has joined the experienced sales team at BEKUM in Berlin as a Sales Engineer.

### Portrait Bill Duckham



Bill Duckham (born 1963) has many years of experience as a Sales Director in Capital Equipment, most recently for a large international packaging machine corporation with high turnover responsibility. Bill Duckham: "I consciously chose BEKUM. The reasons for this were the positive strategic development of the company, short decision-making processes in a medium-sized family business and a great opportunity to actively shape and develop the sales department at BEKUM." The native Englishman studied Electrical Engineering at the University of Manchester (UK). Duckham has a very strong technical background: Duckham's professional career includes milestones as a technical lead which further led him to sales management.

### Portrait Werner Pawlowski



Werner Pawlowski (born 1964) can look back on over 20 years of experience in extrusion blow moulding technology. In the past he had already worked on projects and in sales for BEKUM as well as for a well-known competitor in the automotive branch. After other leading sales endeavours, Werner Pawlowski has now "returned home" to BEKUM. As Global Sales Manager, he will assume responsibility for the automotive, large packaging and technical parts industries. In addition to acquiring new customers and new projects, Werner Pawlowski will also contribute to the implementation of new machine and production concepts with his extensive expertise and his significant network in the blow moulding industry.

### Portrait Stephan Gruber



Stephan Gruber (born 1986) is working as a Sales Engineer for BEKUM in Berlin. As a graduate engineer from RWTH Aachen University, he supports customers in project development and the procurement of application-specific extrusion blow moulding systems. Stephan Gruber also embodies the generational change at BEKUM. He went through an extensive six-month theoretically and practically in-house training programme to ensure that the long-standing years of blow moulding know-how will be safeguarded with the next generation of sales staff.

## Careers at BEKUM – Together for the Success of Our Customers

Are you ready to make a career move? BEKUM, as a globally active company offers you a variety of attractive positions.

Apply now!





## Market Success

# Polycarbonate water bottles

## Higher quantities and performance in water bottle production with BEKUM blow-moulding machines

Polycarbonate (PC) is the most used material in the manufacturing of water bottle containers over 10 litres. This is due to the high mechanical material properties for article stability, suitability for cleaning even at temperatures over 85° C and the crystal-clear transparency. The container size of 5 gallons (18.93 litres) is a widely used standard size with high quantities, suitable for the standard water dispensers available on the market.

BEKUM has configured the **blow-moulding machine BA 25** especially for 5-gallon water bottle production. With the machine components that are optimally adjusted to one another, a high-performance and low-wear machine concept with a compact footprint has been designed for a long service life and long production period.

Modern controls and proportional hydraulics allow a **high output of up to 160 items/hour with fully automated flash removal** in reproducible product quality and with a high efficiency level (reference item "Nestlé 5-gallon Aqua Design without handle" with 750 g net weight).

Production with PC new material, recycled material and material mixtures is possible. This is where BEKUM incorporates its experience from many projects installed worldwide. With the innovative discontinuous **spiral mandrel distribution extrusion head from BEKUM, uniform wall thicknesses over 360° of the water bottle are generated.** Thus fully transparent water bottles with a cloud-free surface and without article thinning or flow marks can be blown. A multi-zone

temperature control of the special blow mould ensures correct temperatures during the blowing process for product forming with the delicate plastic. The polycarbonate water bottles can be manufactured with or without handles. Easy-to-switch interchangeable inserts in the body of the article and bottom area create the **flexibility of being able to produce the same article for several end customers.**

**With these convincing performance characteristics, the expertise from many delivered PC projects in South-East Asia and Latin America, and the system design optimally aligned to PC water bottle production, BEKUM is setting the standards in water bottle production.**

c.richard@bekum.de



PC-water bottle with handle

### Publisher

**BEKUM Maschinenfabriken GmbH**  
 Kitzingstraße 15/19  
 12277 Berlin, Germany  
 Phone: +49 (0) 30 74 90 - 0  
 Fax: +49 (0) 30 74 90 - 2441  
 E-mail: sales@bekum.de  
 www.bekum.de

**BEKUM Maschinenfabrik Traismauer GesmbH**  
 Venusbergerstraße 40  
 3133 Traismauer, Austria  
 Phone: +43 (0) 27 83 4111 - 100  
 Fax +43 (0) 27 83 4111 - 109  
 E-mail: office@bekum.com

**BEKUM America Corporation**  
 1140 West Grand River - Williamston,  
 Michigan 48895 - 0567 USA  
 Phone: +1 (517) 655 - 4331  
 Fax: +1 (517) 655 - 4121  
 E-mail: sales@bekumamerica.com  
 www.bekumamerica.com